



Electricity Engineers'
Association

**ASSET
MANAGEMENT**

Welcome to the FlexTalk Project: Part A Webinar

Please mute your mic and turn off your camera.

Thank you to our presenters and to you our audience for your attendance.

EEA value your support.

Please note. This webinar will be recorded and shared on the EEA website.

EEA.CO.NZ



EEA & EECA

The Electricity Engineers' Association (“EEA”) provides a focal point for collaboration and thought leadership in engineering, safety and asset management across the electricity supply industry.

The EEA enables members to continuously learn and develop in a dynamic and rapidly changing environment.

EECA is a Crown agency, established under the Energy Efficiency and Conservation Act 2000 to encourage, promote and support energy efficiency, energy conservation and the use of renewable sources of energy. EECA’s purpose is to mobilise New Zealanders to be world leaders in clean and clever energy use. It strives for a sustainable energy system that supports the prosperity and well-being of current and future generations.



Electricity Engineers'
Association



Introduction

Today we will share our experience designing, implementing and trialing Flexibility services, utilizing Part A of the OpenADR communications protocol between EDB's & Flexibility Suppliers to achieve active managed charging of EV's



Stuart Johnston
EEA



Rodger Griffiths
ElectroNet



Terry Paddy
Cortexo



Connie Dunbar
EEA



Agenda

- Scene setting – decarbonisation / EV growth
- Future Network Operations, The market model
- Why OpenADR has been selected for trial
- Our implementation of OpenADR (Technical)
- Our trial (customers, flexibility services)
- Our findings (event outcomes, customer experience, EDB experience)
- What did we learn? (wider flex learnings)
- What next?



Speaker 01. Stuart Johnston



Dr Stuart Johnston

Principal Advisor – Engineering & Technical, EEA

Agenda:

- What challenges / opportunities do we face in the energy transition?



Background

- Aotearoa's journey to meet our net zero by 2050 decarbonisation goals will be challenging.
- Electrifying transport and heat, and increasing renewable electricity, will be the most significant contributors to New Zealand achieving net zero carbon by 2050.
- One of the key enablers to support electrification will be the establishment and implementation of demand flexibility mechanisms.



Increase in Aotearoa's Gross Electricity Demand by 2050

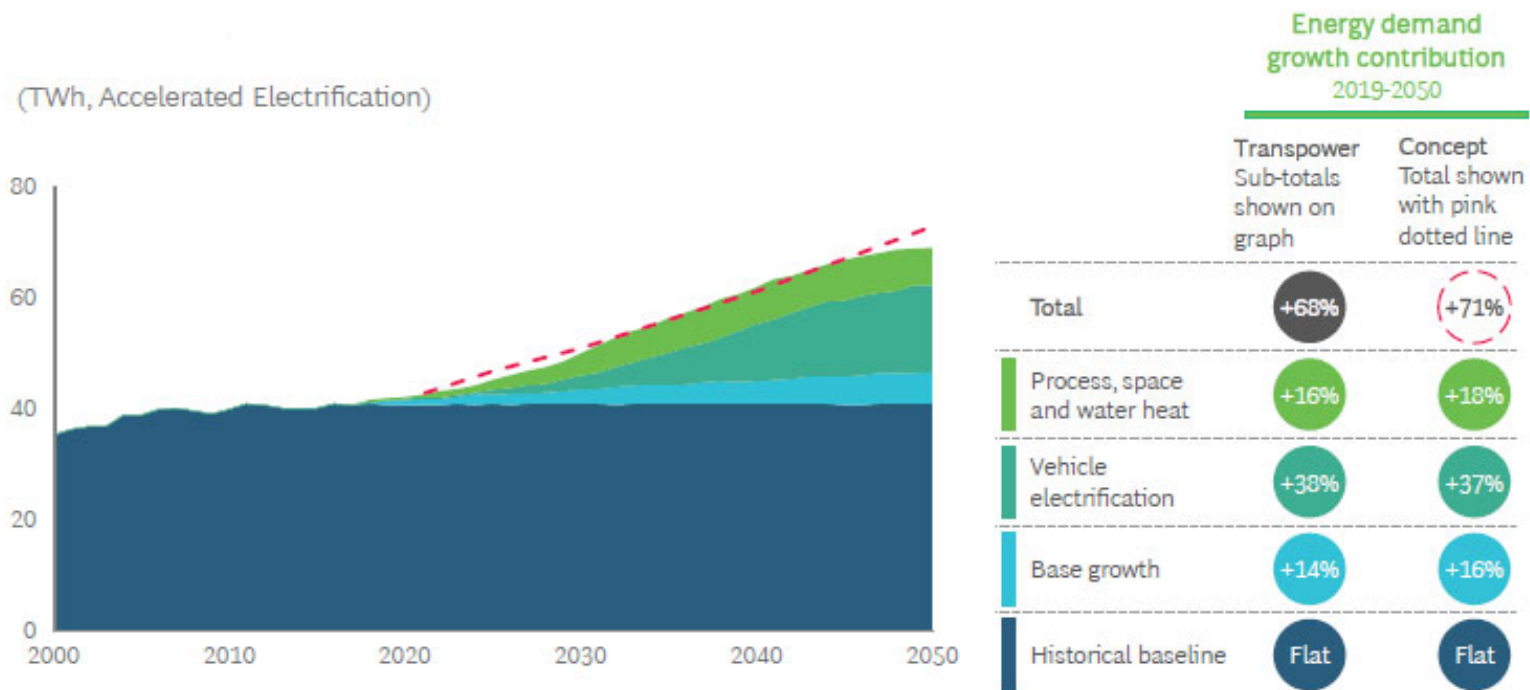

Source: Transpower Whakamama i Te Mauri Hiko (March 2020) - Accelerated Electrification Path; Concept Consulting, BCG analysis



Why is Developing Demand Flexibility Important?

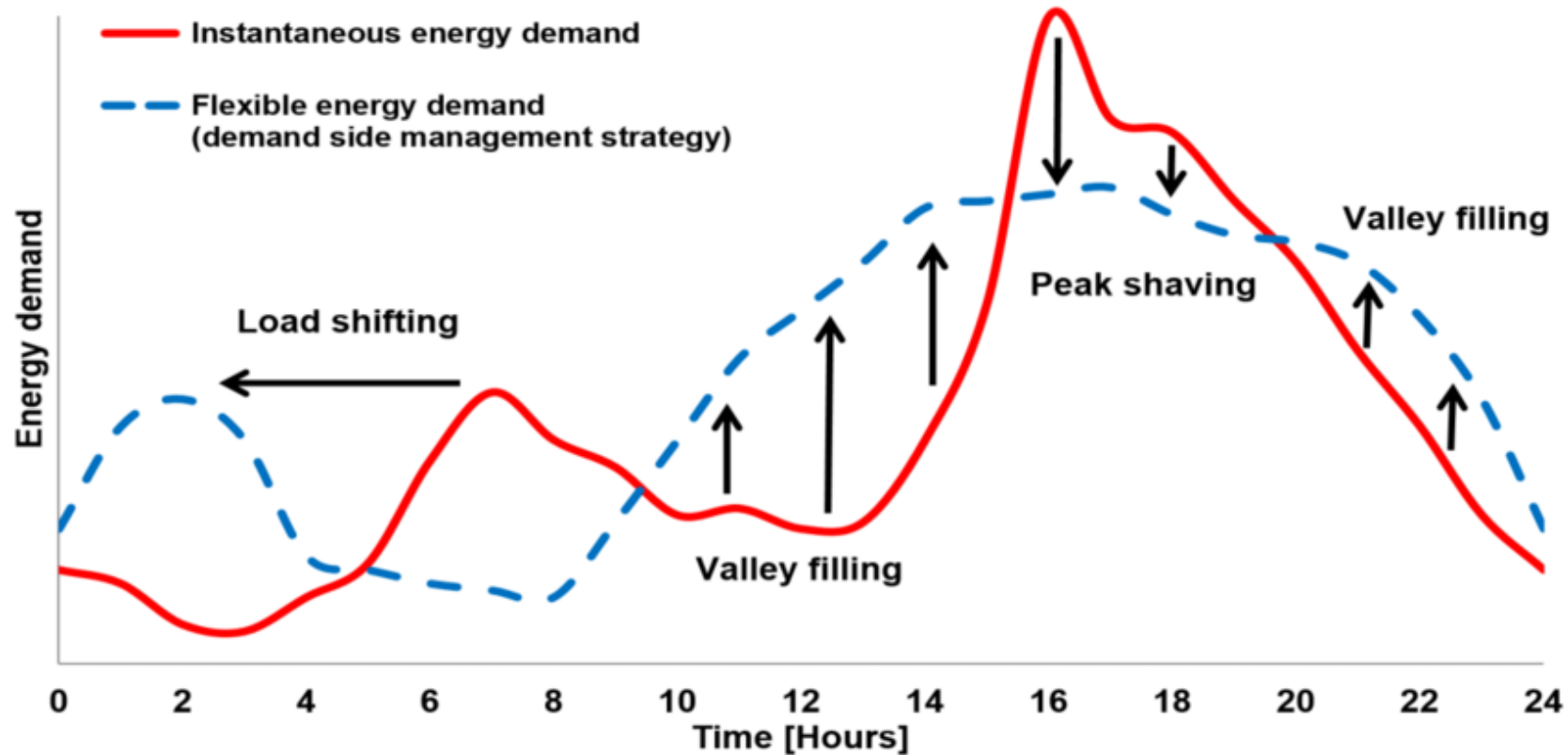

What is Demand Flexibility?

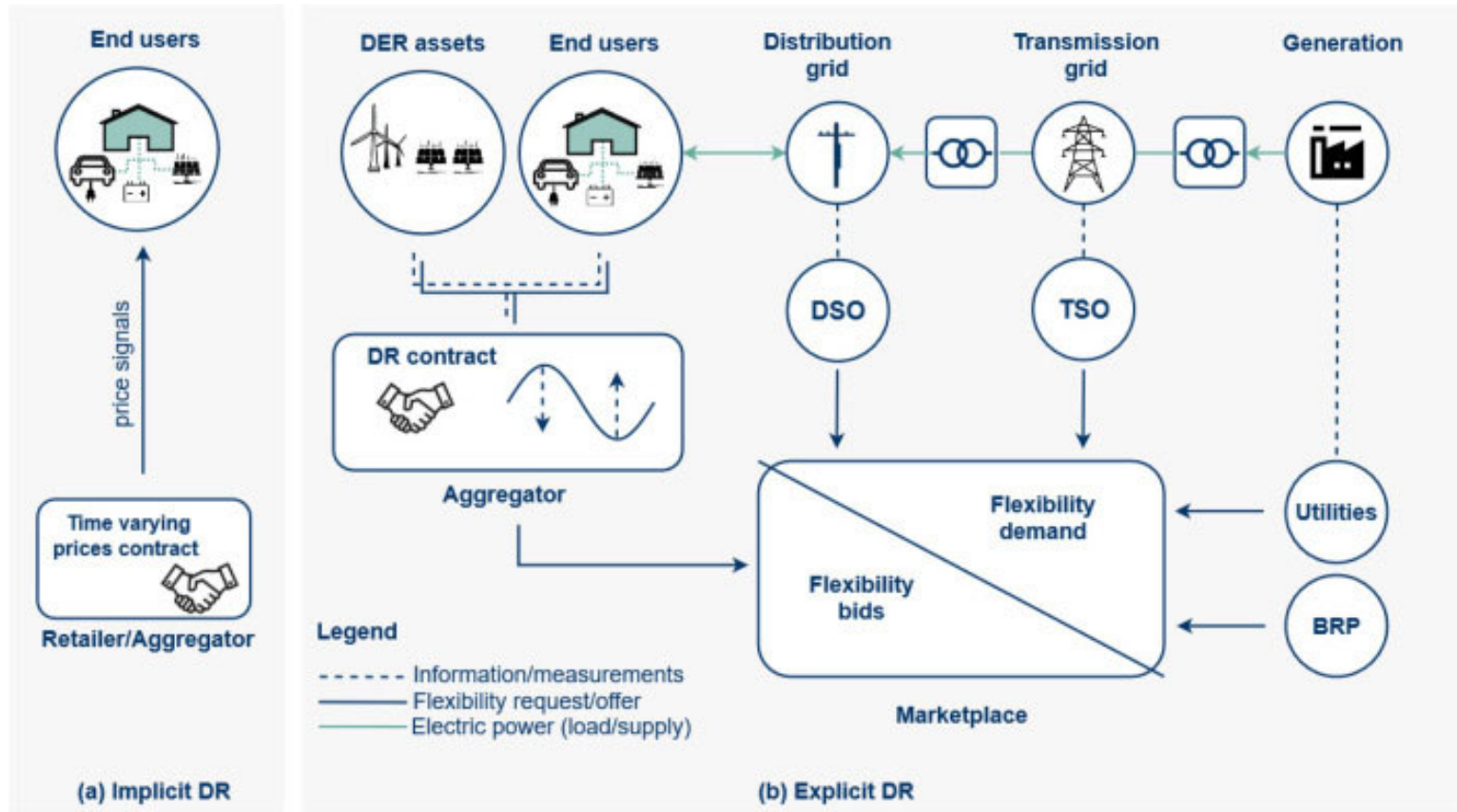

Speaker 02. Rodger Griffiths

General Manager Generation & Technology, Westpower



Agenda:

- Project background



FlexTalk - The Demand Flexibility Common Communications Protocol Project

The project is a collaborative partnership between industry (represented by EEA) and EECA to evaluate the processes that need to be in place to apply the OpenADR 2.0 (2.0a and or 2.0b) communication protocol to achieve active managed charging of electric vehicles (EVs), enabling flexibility services to be utilised in the electricity sector in New Zealand.



Electricity Engineers'
Association



Project Context

- Open communication protocols are internationally acknowledged as a prerequisite to a fully demand flexible electricity system.
- The most successful (and widely adopted) open communication protocols are grounded in international standards.
- OpenADR as a 'dispatch' protocol is ideally designed to deliver an exemplar of functional demand flexibility in NZ.
- OpenADR is ideally configured to interface with the most common communication protocol used in EV chargers globally - OCPP v1.6 and above.



Project Objectives

1. Determine the use cases for flexibility services to be communicated and create process maps for these.
2. Assess the advantages and limitations of OpenADR within the New Zealand context, including a high-level comparison against other communication protocols.
3. Demonstrate interoperability of communication protocols between EDB's, EV flexibility suppliers and consumers.
4. Assist industry participants in understanding the systems investment involved with utilising flexibility services.



OpenADR demonstration - alternate DER type

- The FlexTalk project has the opportunity to bring in wider learnings by including SolarZero as a delivery partner.
- Enables the testing of a battery programme to request flexibility with Solar PV between an EDB and Solar provider.
- Inclusion of Solar Zero allows demonstration of OpenADR with an alternate DER type (PV and batteries) and the ability to compare the API solution (alternate communications protocol)



Our Team

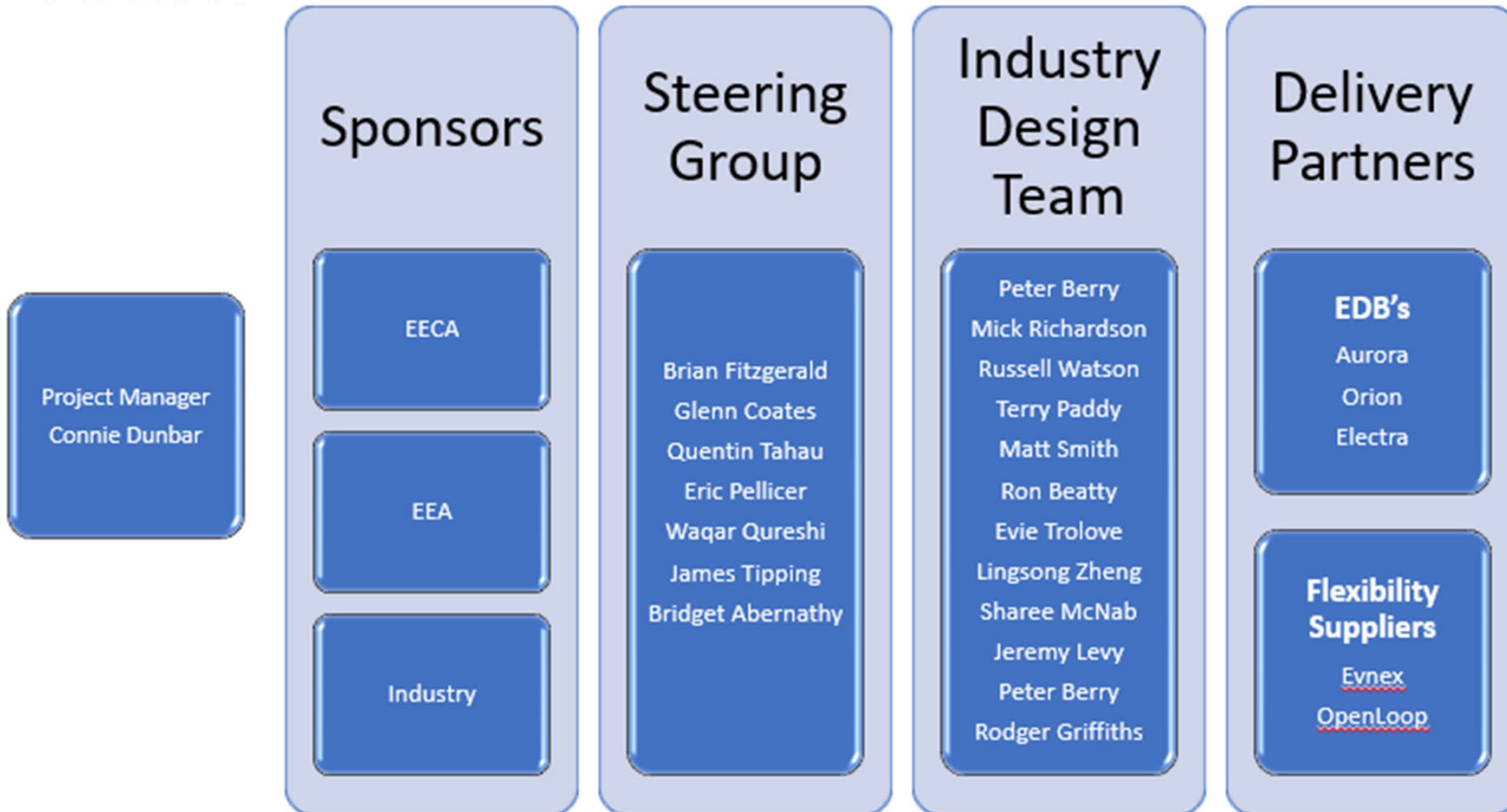

Project Timeline

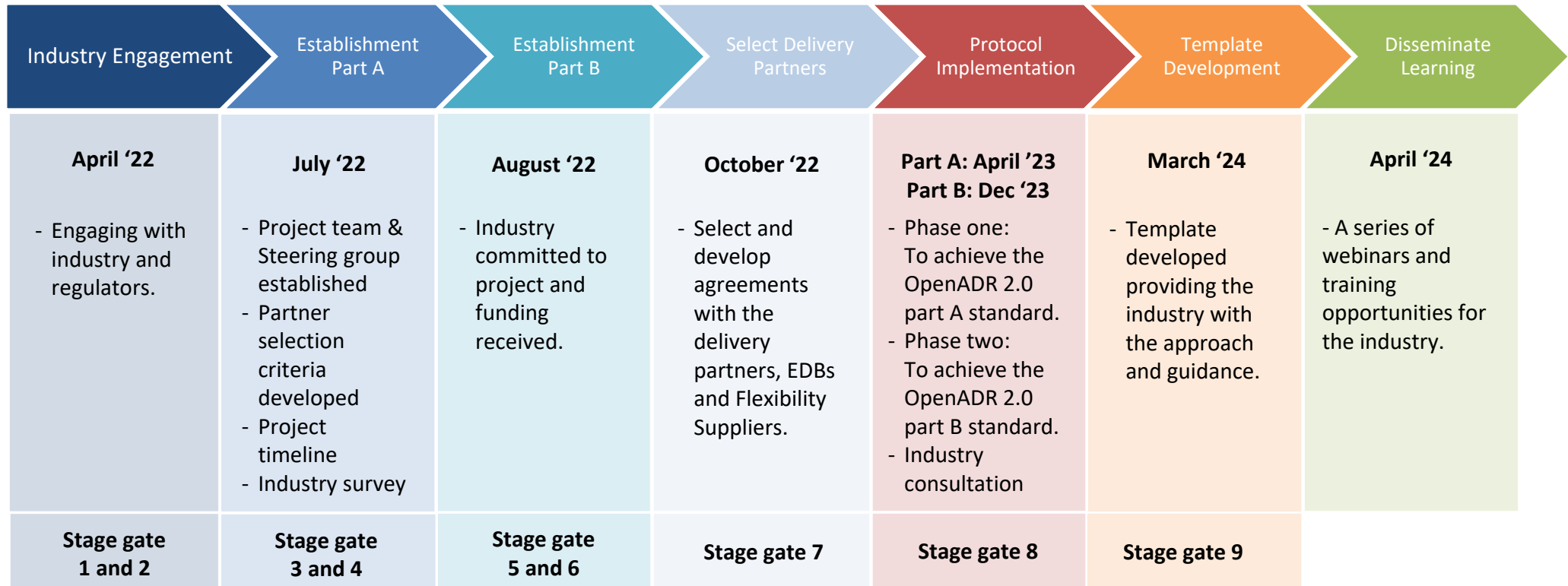

↑
We are here



Electricity Engineers' Association



A Market Led Model

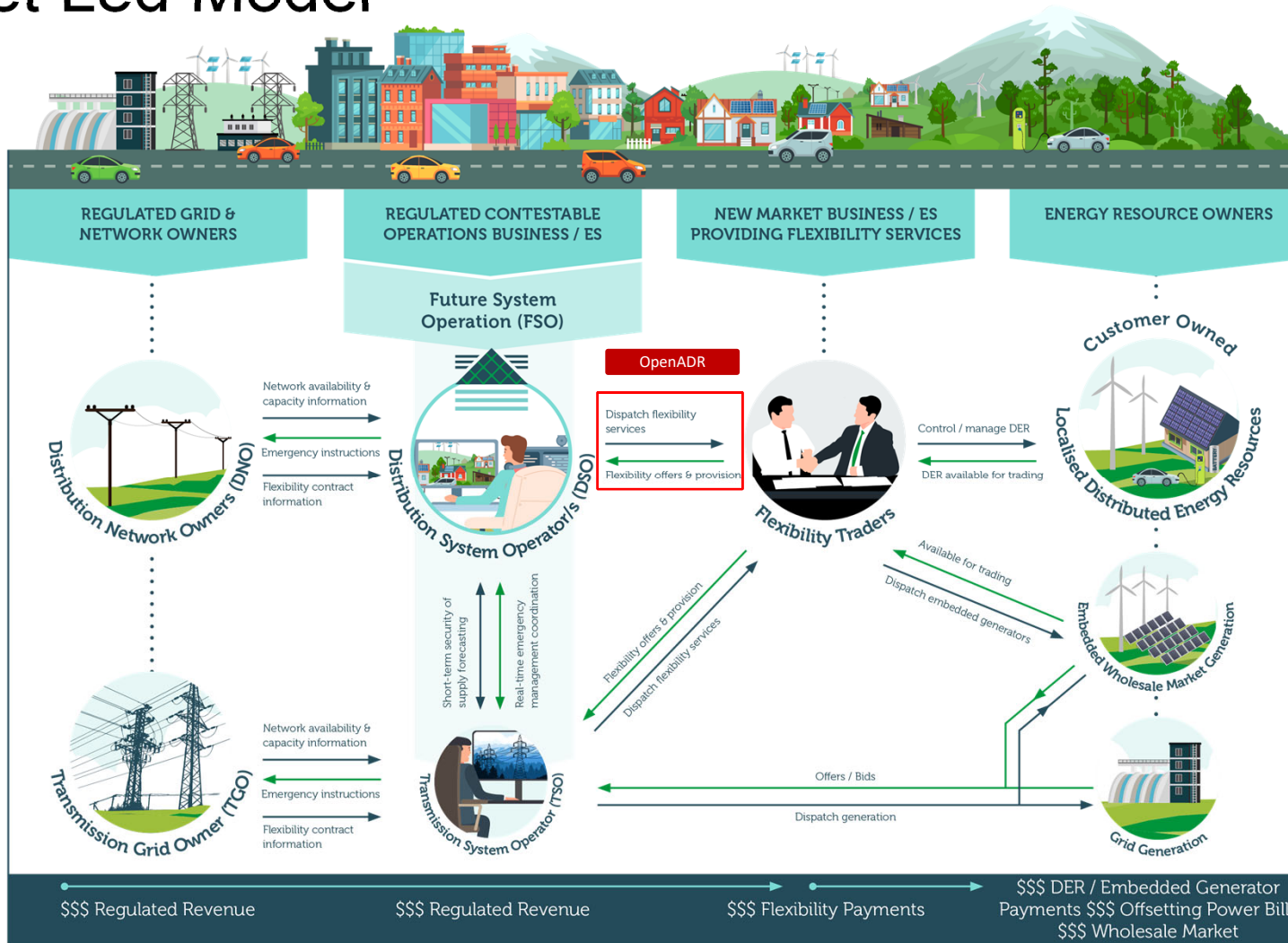

Protocol Selection

OpenADR

Mature demand response protocol

More suited to interfacing EDB's and Flex Suppliers

Transpower already had an operational head end (VTN)

IEEE 2030.5

Used in Australia for PV Management

Suitable for interfacing directly with flexibility hardware

Built on an IoT Concept



Speaker 03. Terry Paddy

Managing Director, Cortexo



Terry Paddy

Agenda:

- Technical Implementation
- FlexTalk flexibility services (programmes)



OpenADR hierarchy

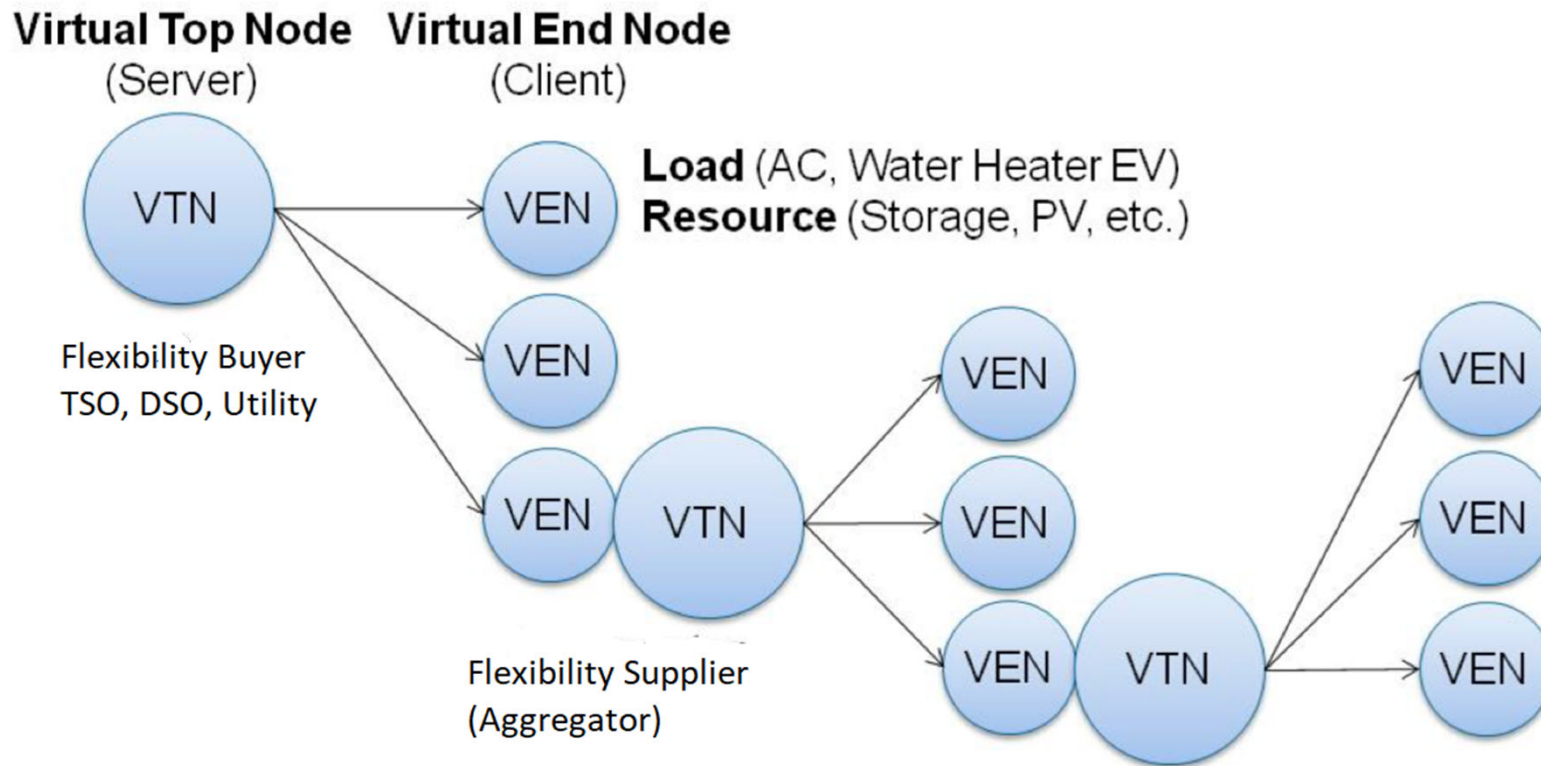

The Project Model

Trial Configurations

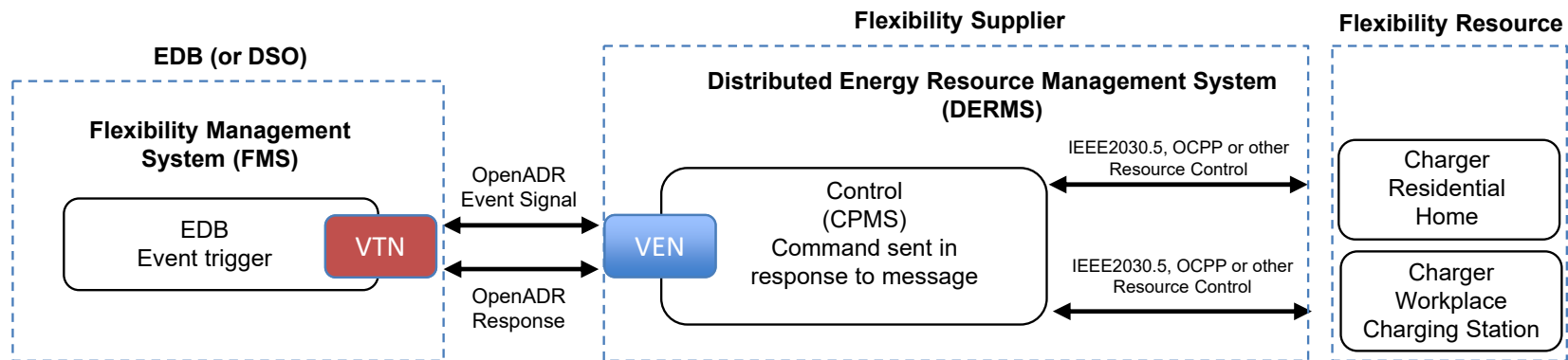
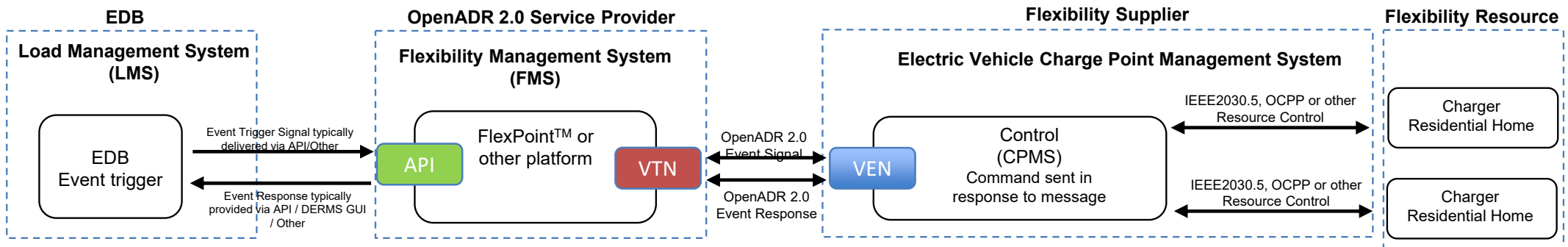

The Project Model

Trial Configurations

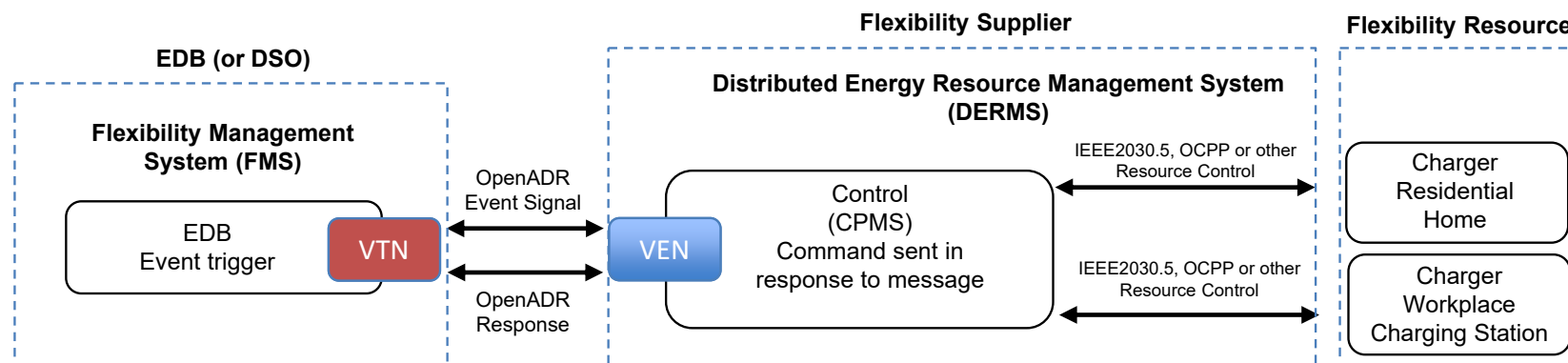

The Project Model

Trial Configurations

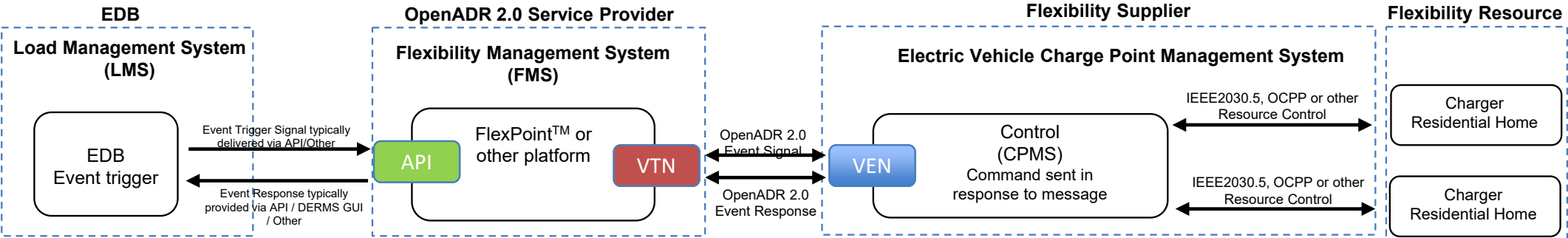

The Project Model

Possible Future State

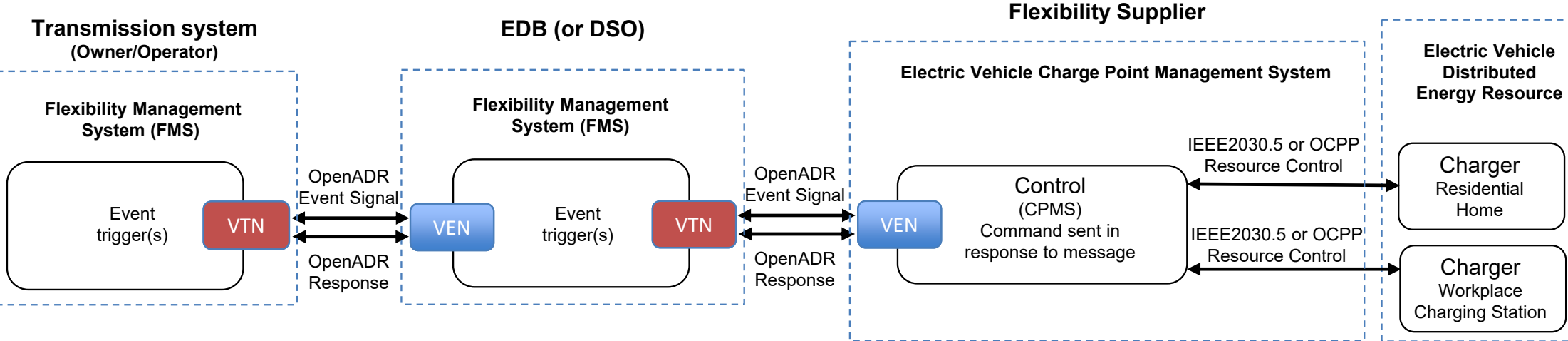

Technical Implementations

EDB's / Flexibility Suppliers

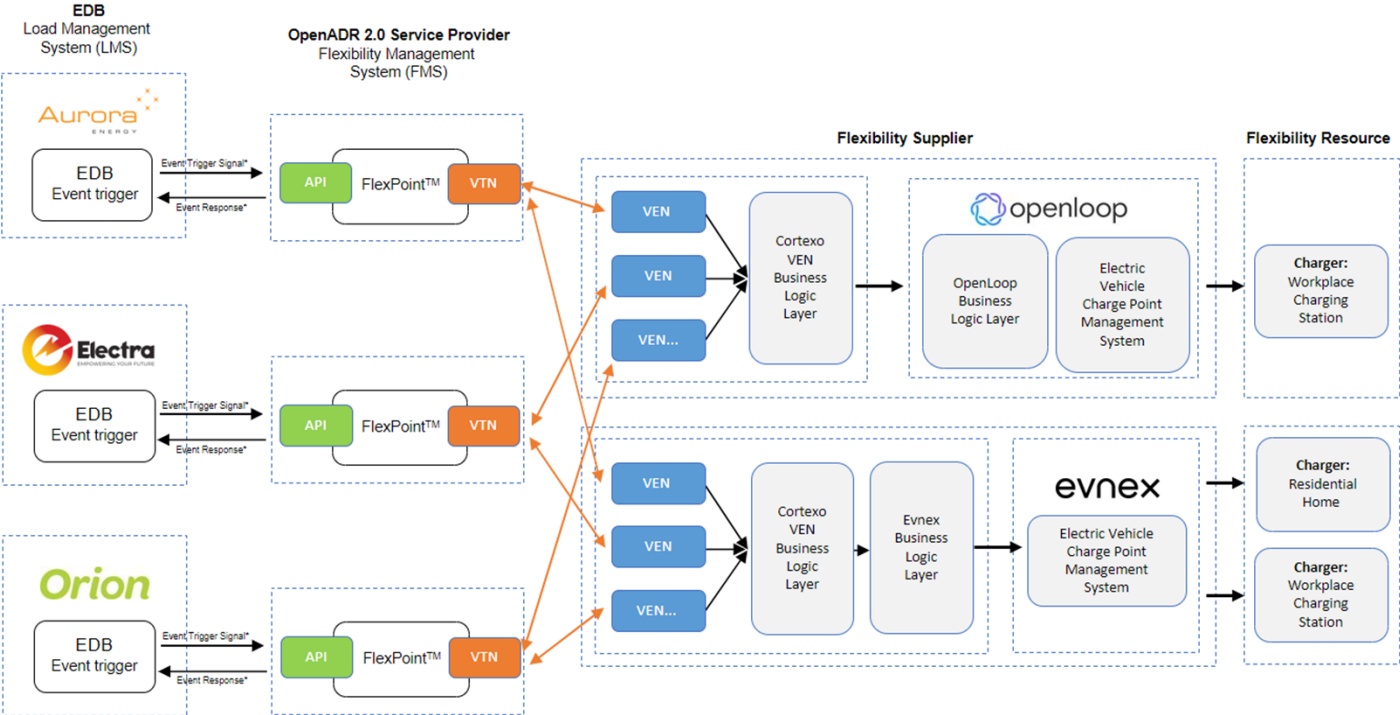

* Event Trigger Signal and Event Response typically provided via API/ DERMS GUI / Other

— OpenADR



Technical Implementations

Using Transpower's Flexpoint®

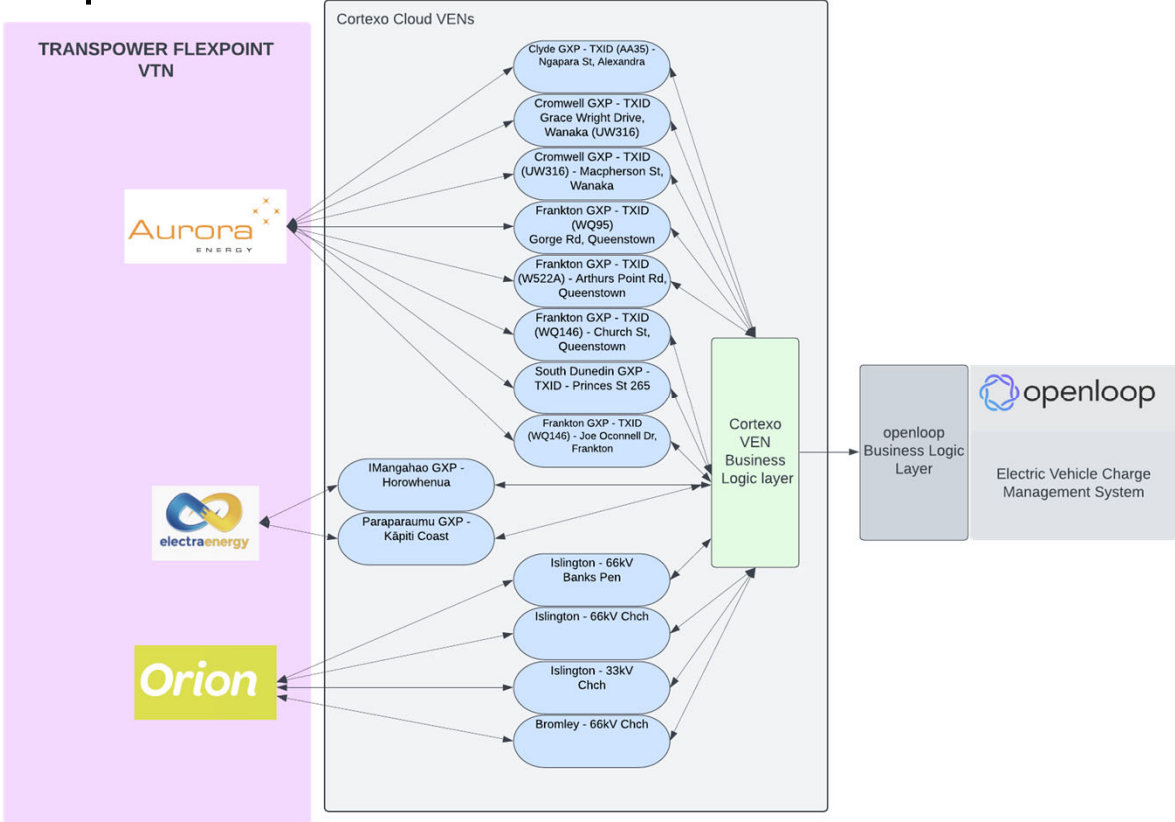

Message Flow – Part A & B

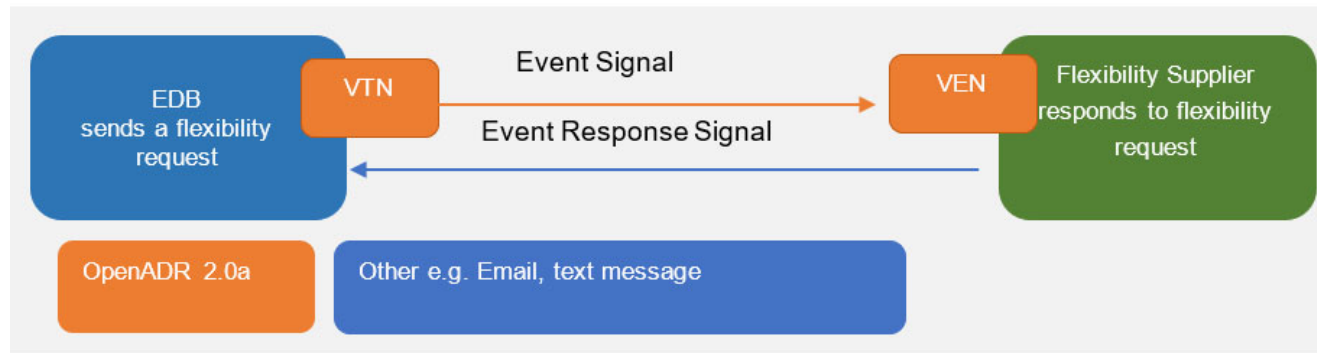

Part A message flow



Part B message flow



Part A

SIMPLE SIGNAL

OpenADR Simple Signal

- 0 – Do nothing
- 1 – Low
- 2 – Moderate
- 3 – High

Meaning

- 0 – Do nothing
- 1 – 50% reduction
- 2 – 75% reduction
- 3 – 100% reduction

Reduction from a set
baseline capacity

Part A Programmes

1. In Advance
2. Immediate (Dynamic)
3. Price Responsive Bid
4. Price Responsive Discovery



Part A Programmes

- Discuss dynamic and emergency programmes

PROGRAMME	BASELINE		LEVEL	LEVEL	LEVEL	LEVEL
			0	1	2	3
Programme 02 Dynamic Short Term Non-Price Responsive	Flex Capacity a.m.	Flex Capacity p.m.	0%	50%	75%	100%
Programme 03 Immediate Emergency Non- Price Responsive	Flex Capacity a.m.	Flex Capacity p.m.	0%	50%	75%	100%



What's in Part B?

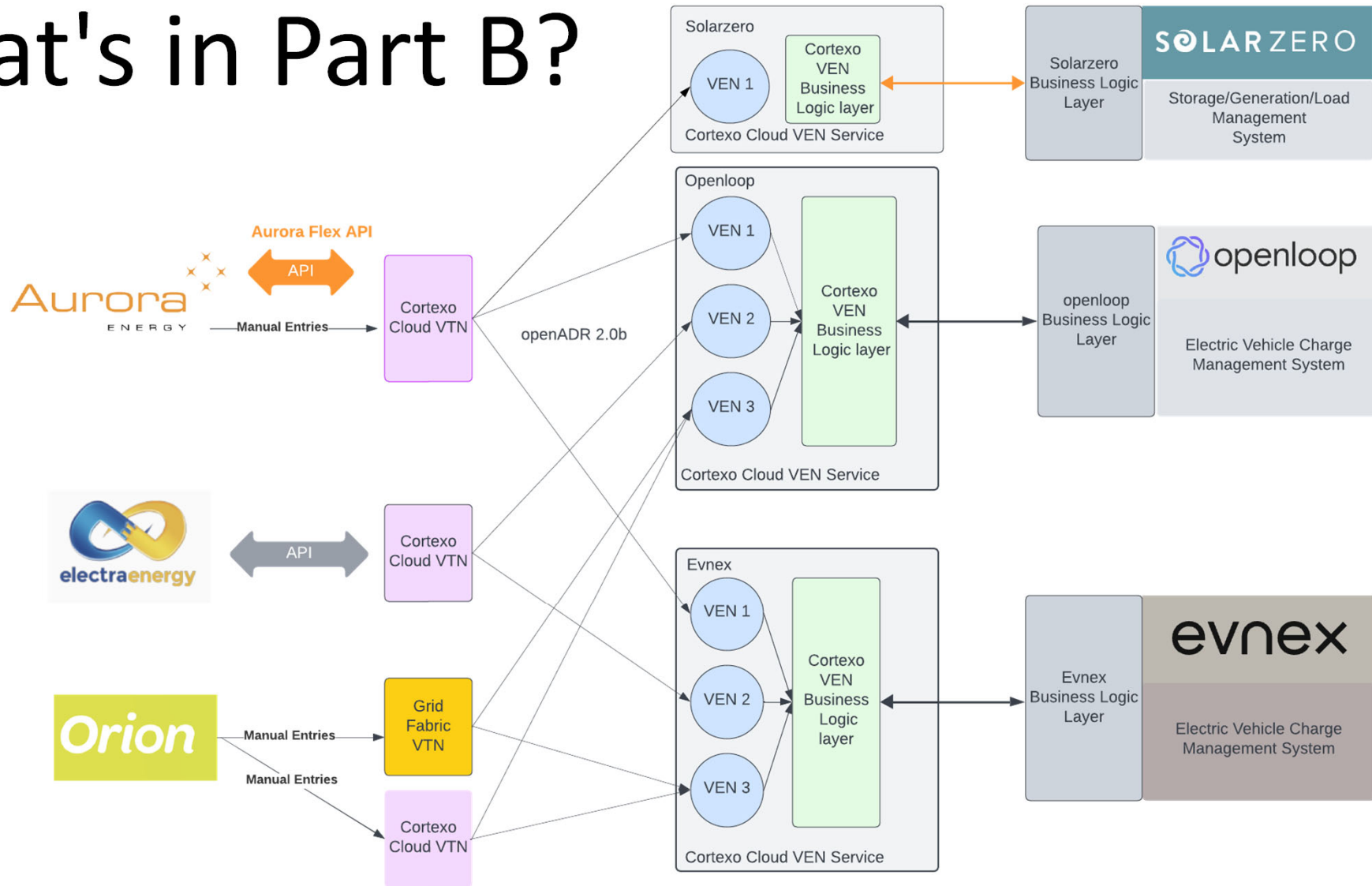

Complex Signals, API & Reporting

- In Advance
 - Load Dispatch – delta kW
- Immediate (Dynamic)
 - Load Dispatch – delta kW
- Emergency
 - Simple – 3 (!00%)
- PR Bid
 - Load Dispatch – delta kW
 - Electricity Price - \$/kWh
- PR Discovery
 - -Load Dispatch – delta kW
 - (optional) Electricity Price - \$/kWh
- Dynamic Operating Envelope
 - Max import
 - Min import
 - Max export

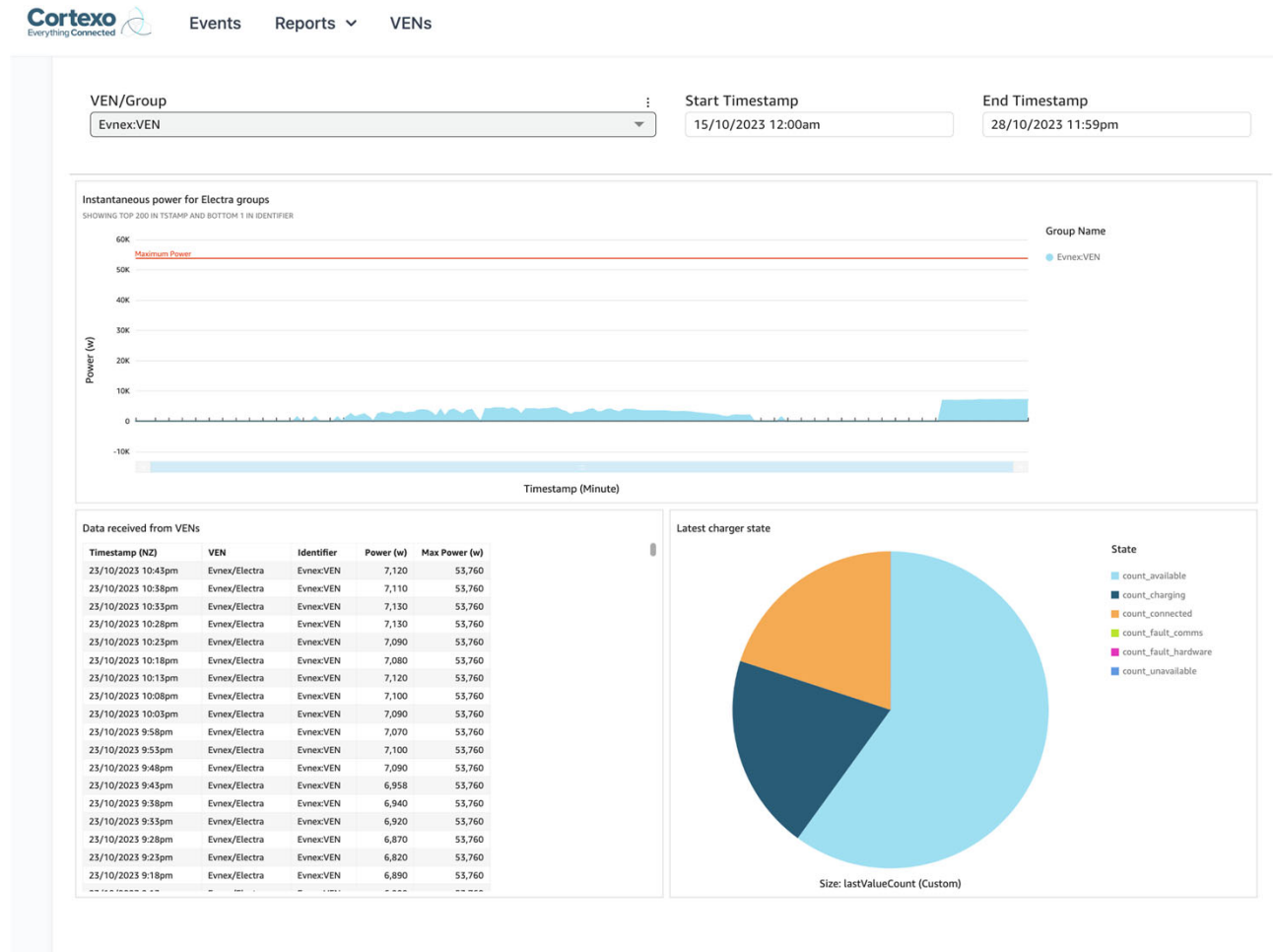

Speaker 04. Connie Dunbar

FlexTalk Project Lead, EEA



Connie Dunbar

Agenda:

- Part A Trial approach
- Part A Trial outcomes
- Wider Flexibility learnings



Part A – Designing Flexibility Programmes

- IDT Workshops to determine flexibility programmes
- EDBs – what do they need / want? (requirements for requesting flexibility)
- Flexibility suppliers – what can they provide? (what flexibility, what data)
- Determined triggers, programme behaviour and the type of interactions actors would participate in



Part A – Trial Approach

Customers

- 49 customers
- Mix of residential / commercial
- 89 chargers targeted during Part A



Part A – Trial Approach

Testing Schedule

- 3-4 events deployed per week
- Trial schedule
- Learnings canvas
- Assessment of events against success criteria



Event Overview

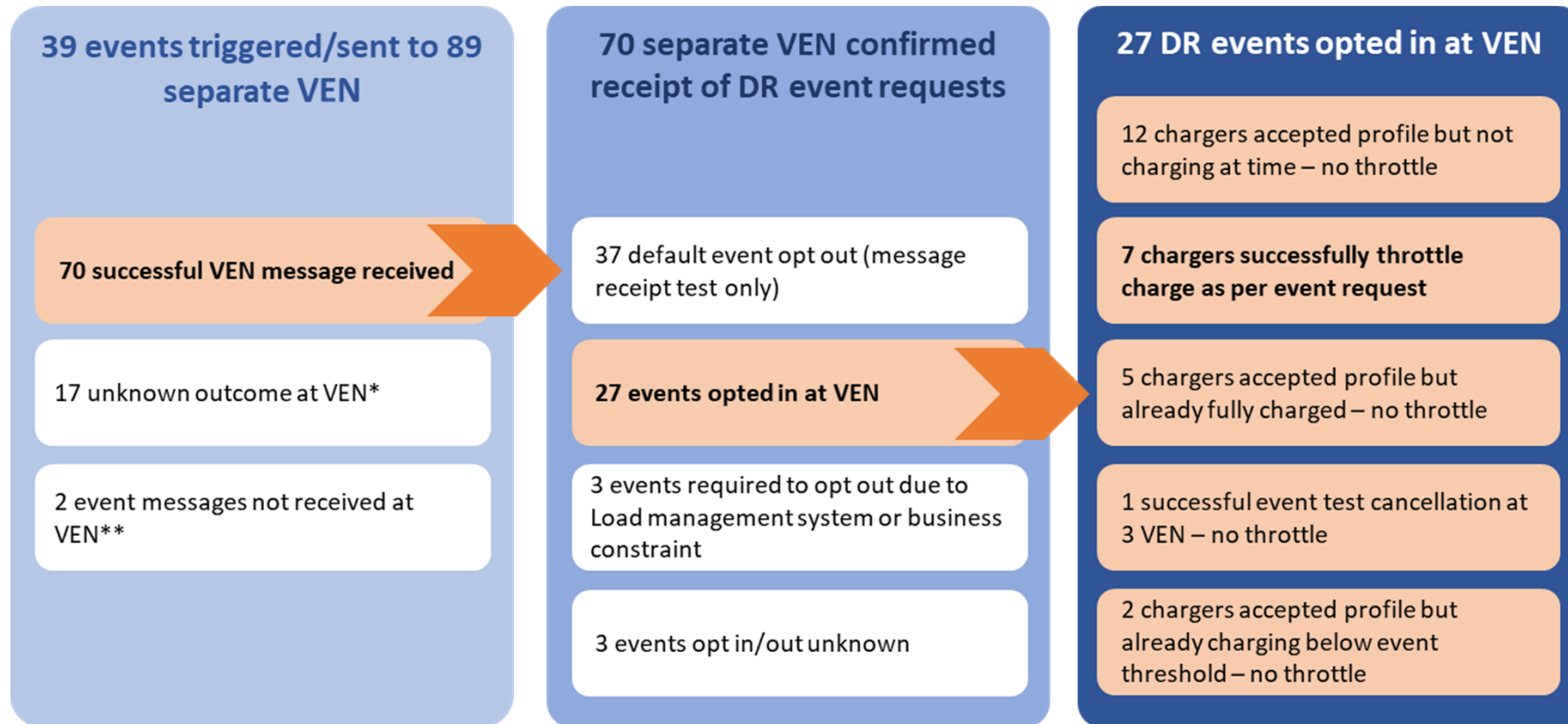

*Due to limitations with data capture

**If the DR Level is not set in FlexPoint Flexibility Management System or the DR request is set to 0 kW, then no OpenADR events will be created.



Customer Feedback

Customer surveyed at conclusion of Part A to assess:

- Awareness of active managed charging
- Impacts on charging routine / behaviour
- Potential financial impacts
- Further participation in EV charging trials
- Residential and commercial question set with Y/N and ability to comment



Customer Feedback

- No material impact reported, aware of throttle down but no disruption to charge availability
- Some customers mentioned the trial did impact their charging behaviour but didn't specifically call out how
- Commercial customers didn't notice a financial impact of participation in trial
- Residential customers did call out that the trial did impact their free hour of power
- Most respondents were willing to participate in demand flexibility events in future
- For commercial customers, they don't fully understand the commercial or customer value proposition



Delivery Partners Commentary

Learning curve for Part A:

- Terminology
- Interpretation
- Learning systems (FlexPoint)
- Exploring integration approaches - predominantly manual for Part A
- General call-out that the technology works but the wider implication of participation in demand flexibility need to be considered for this to be operationalised / scaled up



Delivery Partners Commentary

“None of this has been what I would call hard, it’s all work which needs doing and takes time and money, but the actual technical development has been a matter of working through a very familiar engineering process involving technical building blocks that I recognise from lots of other similar work. Scaling up will be much more a problem of commerciality and social license than a problem of technology”

– Tom Rose, Evnex



Electricity Engineers'
Association



What else did we learn?

BUSINESS / COMMERCIAL

- Contractual agreement design needs to be considered and will ultimately inform how actors participate in flex events

CONSUMERS

- Consumer buy-in, need to bring awareness to demand flexibility to gain social license
- Evidence from trial recruitment process suggests that some customer segments may be more sensitive to the impacts of demand flexibility.
- Customer privacy and obligations must be considered when designing data sharing approach. How do we balance customer data privacy with the availability of data to participate in flex events? E.g. Sharing ICP

TECHNICAL

- Need ability to access smart charging functions with all charger types. It was discovered during trial that troubleshooting required to access / control chargers for a key manufacturer.
- Load management building rules may impact the ability for charger to accept smart charging profiles and thus inhibit access to assets for demand flexibility
- It is essential that interpretation of terminology and behaviour is understood across actors participating in DF events.

MARKET

- Work is needed to understand the end-to-end impact and understand the key roles in energy supply chain as well as the business models and business case for investment



Where to next?

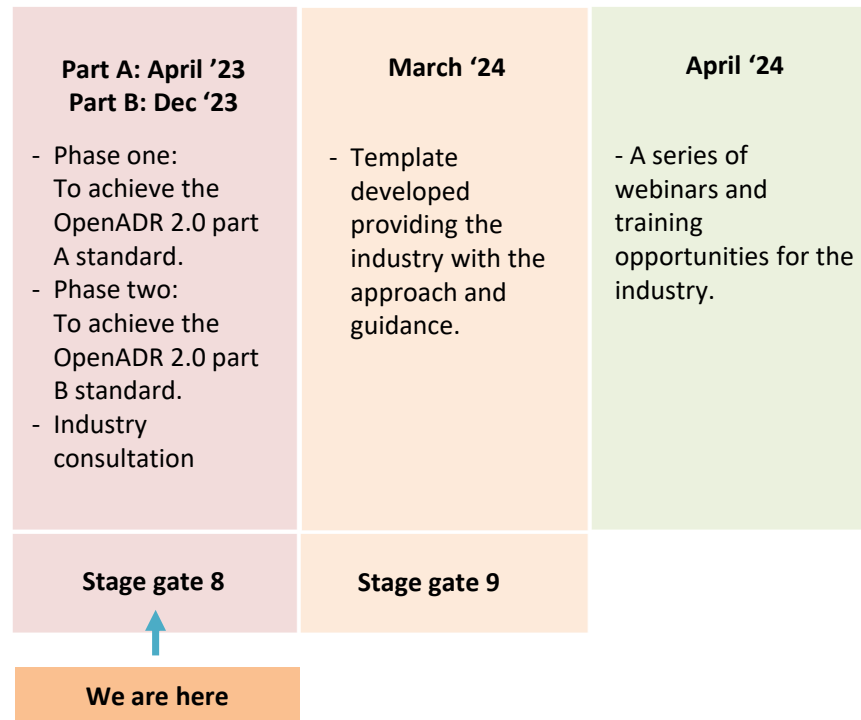

Where can I learn more?

- Part A Report (EEA website)
- Asset Management Forum – 2nd November, Christchurch



Thank you



Questions



Stuart Johnston
EEA



Rodger Griffiths
ElectroNet



Terry Paddy
Cortexo



Connie Dunbar
EEA





Electricity Engineers'
Association



ASSET MANAGEMENT



Please note. This webinar will be recorded and shared on the EEA website.

EEA.CO.NZ

